



Part-turn actuators

for OPEN - CLOSE and modulating duty

SG 05.1 – SG 12.1

SGR 05.1 – SGR 12.1

SGExC 05.1 – SGExC 12.1

Torques up to 1,200 Nm





Applications

AUMA part-turn actuators are used wherever the automation of a valve requires rotary movement of 360° or less, e.g. when using butterfly valves or ball valves. The actuators can be adapted to suit the requirements of nearly all valve applications. This is achieved by:

- a wide torque and operating time spectrum,
- various combination possibilities with AUMA actuator controls,
- a large variety of versions.



Energy

- : Power plants
- : Air pollution control
- : District heating
- : Pipelines



Water/Wastewater

- : Water works
- : Sewage treatment plants
- : Pumping stations
- : Dams



Chemical industry

- : Chemical industry
- : Petrochemical industry
- : Pharmaceutical industry



Others

- : Oil and gas industry
- : Air conditioning
- : Ship building industry
- : Steel mills
- : Cement plants
- : Food industry

Contents	
Applications/duty types	4
Modular design/versions	6
Design principle	8
Summary of applications, functions, and equipment	9
Service conditions	10
Functions	12
Signals/indication	17
Integral controls	20
Valve attachment	21
Electrical connection for non-explosion-proof actuators	22
Electrical connection for explosion-proof actuators	23
Technical data	24
Certificates	26
The actuator specialist	27
Literature	28
Index	29
AUMA worldwide	30

Solutions for a world in motion

This brochure will provide both the beginner and the expert with an overview of functions and applications for AUMA part-turn actuators SG 05.1 – 12.1. It can serve as a basis to determine whether a device is suitable for the chosen application.

For detailed product selection refer to the separate data sheets and price lists. On request, AUMA engineers within field service and within our subsidiaries can help you to find the correct device for the application.

AUMA SG part-turn actuators have been manufactured and used successfully since 1983. Ever since the actuators have been continuously improved.

The part-turn actuators SG 05.1 – SG 12.1 can be combined with latest generation AUMA actuator controls – this is enabled by the modular design principle of the AUMA product range. Both the mechanical interface as well as options for integration into a DCS are always up to date.

The latest detailed information on the SG and SGR part-turn actuators can be found on the Internet under www.auma.com. All documents, including dimensional drawings, wiring diagrams and final inspection records for supplied actuators are available on the Internet in a digital form.

Applications/duty types

AUMA automates valves; to put it in a nutshell, this is what AUMA actuators do. In other words: AUMA actuators can be used for remote control of valves; either by an operation command manually triggered in the control room or within the framework of an automated process flow. AUMA is an electric actuator specialist.

According to the different valve designs, there are multi-turn, part-turn and linear actuators. This brochure puts the focus on part-turn actuators. Part-turn actuators are used for the automation of all kinds of part-turn valves. Butterfly valves or ball valves are the most common representatives of these valve types. For complete travel, less than one rotation at the valve input is required. In most cases the swing angle is 90°.

Shutting off, positioning, controlling

The second important selection criterion after the type of movement is the type of duty. Is the valve to be used as a shut-off device (open-close duty), is the valve to be positioned in mid-travel (positioning mode) or is the valve position to be changed at short interval, i.e. to control the flow through a pipeline (modulating duty)? These are essential factors for sizing the valve and the actuator as the load may vary considerably depending on the operation mode.

Consequently, there are AUMA actuators for open-close and positioning duty as well as actuators which meet the high requirements of modulating duty.

OPEN-CLOSE duty and positioning duty

OPEN-CLOSE duty

The valve is operated relatively seldom, the time intervals can span between a few minutes up to several months.

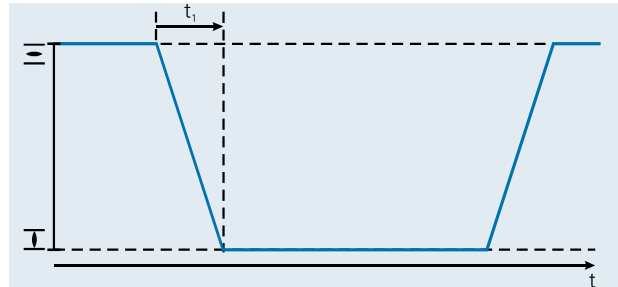

Typical operation in open-close duty

[t₁] Running time. The maximum permissible running time without interruption is usually 15 min, optionally 30 min.

Positioning duty

The valve is operated to a specified intermediate position, e.g. to set a consistent flow rate. The same running time limits as in open-close duty apply.

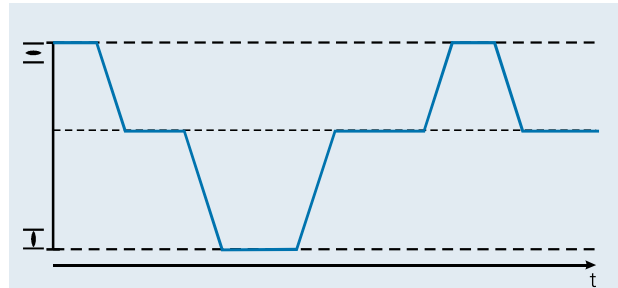

Typical operation in positioning duty



AUMA part-turn actuators in the desulphurisation unit of a power plant.



AUMA part-turn actuators mounted to butterfly valves in a Vietnamese water treatment plant.

Modulating duty

The most distinctive feature of a closed-loop application is that changing conditions require frequent adjustment of the MOV. Sensitive closed-loop applications require adjustments within intervals of a few seconds.

The demands on the actuator are high. Mechanical components and the motor must be designed correctly to withstand a large number of operations over a long time with no decline in the modulating accuracy.

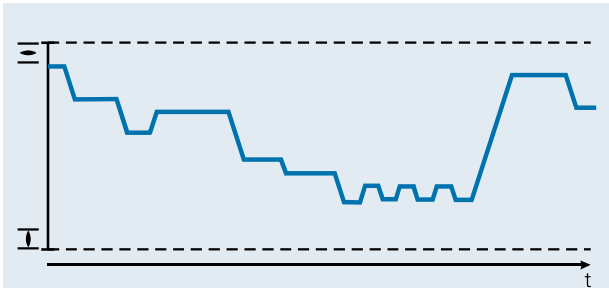

Typical operation in modulating duty

Types of duty of AUMA part-turn actuators

The correct AUMA actuator for the duty can be determined by the type designation.

Part-turn actuators for open-close and positioning duty

AUMA part-turn actuators for open-close and positioning duty are identified by the type designations SG und SGExC.

- As standard, the part-turn actuators SG 05.1 – SG 12.1 conform to the S2 - 15 min duty.
- As standard, the explosion-proof actuators SGExC 05.1 – SGExC 12.1 conform to the S2 - 10 min duty.

Part-turn actuators for modulating duty

AUMA part-turn actuators for modulating duty are identified by the type designation SGR. For modulating duty, the actuator has to be equipped with a 3-phase AC motor as a prerequisite. SGExC explosion-proof part-turn actuators are not approved for modulating duty.

- As standard, the part-turn actuators SGR 05.1 – SGR 12.1 conform to the S4 - 25 % duty.



AUMA part-turn actuators with AUMA MATIC integral controls in a tank farm in Poland.

Modular design/versions

Modular design – with or without controls

Each application has its special requirements. For this reason, AUMA only builds actuators on demand – tailor-made to customer requirements. Due to the modular design of the AUMA product range, different features can be combined. For each actuator type, there is a large number of equipment variants.

One of the fundamental benefits of AUMA's modular design is the ability to add integral controls to the basic actuator.

Actuators without integral controls

If your plant design requires the control of the actuators from a central point, e.g. from a PLC, AUMA supplies actuators without controls, the so-called AUMA NORM version. NORM actuators supply unprocessed signals; the external controls have to process all signals to and from the actuators according to the operation.

NORM actuators have no switchgear for switching the actuator motor on or off. This switchgear, e.g. reversing contactors, has to be included within the external controls to ensure, for example, that the actuator motor is automatically switched off if the actuator signals that an end position has been reached.

AUMA NORM actuators have no operating elements to operate the actuator electrically in the local mode. If this is required, separate local controls have to be installed and integrated into the control system.

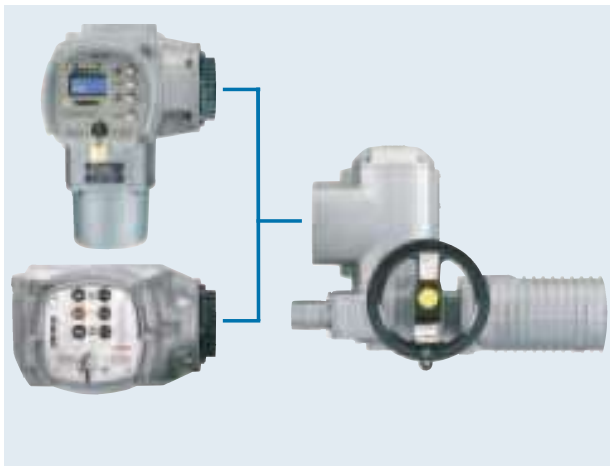

Due to the modular design principle, the part-turn actuator may be supplied without controls or with AUMA MATIC or AUMATIC integral controls.

Actuators with integral controls

After establishing the power supply, the actuators are ready for operation immediately. The actuator signals are processed locally. The required switching procedures are immediately performed within the integral controls, using the integral reversing contactors or thyristors.

After connecting the power supply, the actuator can be operated immediately in the local mode, using the local controls.

Extensive installation work for external controls is no longer required.

The automatic phase correction ensures the correct direction of rotation even if the phases are crossed over during electrical installation.

The high functionality of the controls relieves the DCS, so data exchange is reduced to a minimum.

Integral controls are a prerequisite when connecting actuators to a fieldbus.

NORM actuators can also be retrofitted or supplemented at a later date.

For further information on the integral controls refer to page 20 and the separate brochures:

- Product description
Actuator controls AUMA MATIC
- Product description
Actuator controls AUMATIC



[1]



[2]



[3]



[4]

**[1] Part-turn actuators
SG 05.1 – SG 12.1/SGR 05.1 – SGR 12.1
without integral controls
(AUMA NORM)**

- Torques from 100 to 1,200 Nm
(Illustration with 3-ph AC motor)

**[2] Part-turn actuator
with AUMA MATIC integral controls**

The AUMA MATIC is ideal for simple OPEN - CLOSE applications (open-close duty) and for conventional control. If equipped accordingly, it can also be used for closed-loop control. Further information on page 20. (Illustration with 1-phase AC motor)

**[3] Part-turn actuator
with AUMATIC integral controls**

The AUMATIC is the all-rounder among AUMA controls. It is equipped with a microcontroller and has a lot more functions than the AUMA MATIC. The AUMATIC is ideal for closed-loop control applications. And it is also the AUMATIC that is used for the implementation of the latest fieldbus system developments. Further information on page 20. (Illustration with 3-phase AC motor)

**[4] Part-turn actuator
with the controls on a wall bracket**

The controls can also be mounted separately from the actuator on a wall bracket. This is recommended if:

- limited space restricts the access to directly mounted controls
- high ambient temperatures in the surroundings of the actuator could affect the electronics,
- heavy valve vibration could influence the controls.

(Illustration with 3-ph AC motor)

Design principle

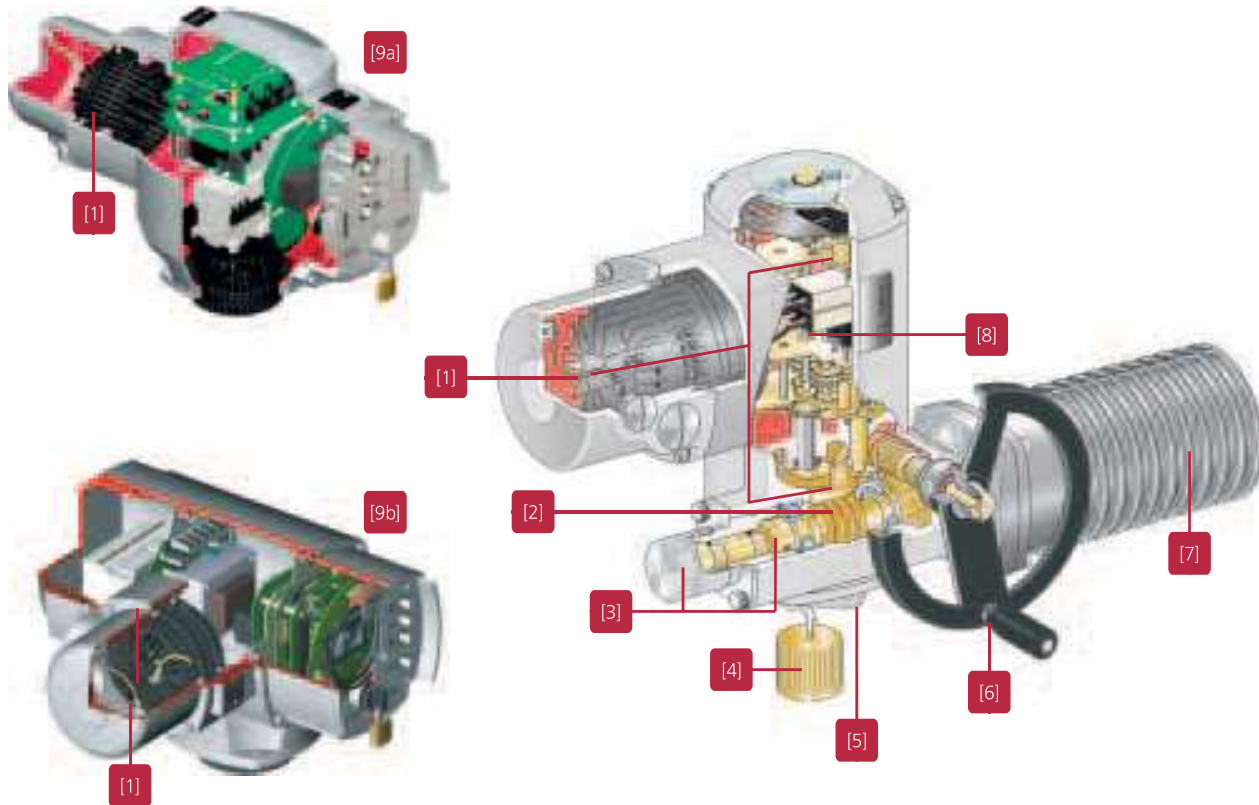

[1] Electrical connection

The electrical connection is made via a plug/socket connector, no matter whether the actuator is equipped with or without controls. For maintenance work, the actuator can be disconnected quickly from the power supply and control cables and easily reconnected. Further information on page 22.

[2] Gearing

The well proven principle of worm gearing, combined with a planetary gear, is used to reduce the motor speed to the required actuator output speed. Self-locking is also achieved by the worm gearing (see also page 16).

[3] End stops

When operating the actuator manually the end stops define the end position, provided the valve has no end positions.

[4] Coupling

The separate coupling enables easier mounting of the actuator to the valve. On request, the coupling is supplied with a suitable hole. The coupling with bore is placed on the valve shaft and secured against axial movement. Subsequently the actuator is fitted on the valve flange (refer also to page 21).

[5] Valve attachment

The valve attachment is designed according to EN ISO 5211. The actuator can be positioned on the valve at every 90°.

[6] Handwheel

For commissioning or in an emergency the part-turn actuator can be operated with the handwheel. Pull the handwheel until it disengages. Manual operation is designed as an over-riding gear arrangement. A change-over for manual operation is not required.

[7] Motor

The actuators are equipped with 3-phase AC motors (as illustrated), 1-phase AC or DC motors. The motors distinguish themselves by a high starting torque to unseat the valve from the end position. The motor is connected via an internal plug/socket connector. This enables quick exchange of the motor e.g. for changing the operating time. Further information on page 12.

[8] Control unit

The control unit includes two measuring systems (limit switching and torque switching) which measure the travel or the torque present at the output drive. Further information on page 14.

[9] Integral controls (option)

AUMA actuators with AUMA MATIC [9a] or AUMATIC [9b] integral controls are ready for operation as soon as the supply voltage has been connected. The actuator can easily be operated on site via the local controls. Via the installed switchgear, i.e. reversing contactors or thyristors, the integral controls automatically and immediately perform the required motor switching procedures. The electrical connection between integral controls and actuator is made by using a plug/socket connector. Further information on page 20.

Summary of applications, functions, and equipment

Standard ● Option ■	SG 05.1 – 12.1	SGR 05.1 – 12.1	SGExC 05.1 – 12.1	Page
Applications/duty types				
Open-close duty	●	–	●	4
Positioning duty	●	–	●	4
Modulating duty	–	●	–	5
Service conditions				
Enclosure protection IP 67	●	●	●	10
Enclosure protection IP 68	■	■	■	10
Low temperature version	■	■	■	10
Corrosion protection KN	●	●	●	11
Corrosion protection KS, KX	■	■	■	11
Explosion protection	–	–	●	11
Functions				
Motor operation	●	●	●	12
Manual operation	●	●	●	8, 13
Limit seating	●	●	●	13
Torque seating	●	●	●	13, 14
Limitation of the swing angle in manual operation	●	●	●	8
Overload protection of the valve	●	●	●	14, 15
Protection against unauthorised operation	■	■	■	15
Protection of the motor against overheating	●	●	●	16
Protection against accidental changing of the valve position	●	●	●	16
Feedback signals¹/Indication				
Valve end positions	●	●	●	18
Valve position	■	■	■	18, 19
Intermediate positions	■	■	■	18
Actuator/valve is running	■	■	■	18, 19
Fault (excessive temperature)	●	●	●	18
Fault (torque fault)	●	●	●	18
Integral controls				
AUMA MATIC	■	■	■	20
AUMATIC	■	■	■	20
Valve attachment according to EN ISO 5211				
Coupling unbored	●	●	●	21
Extended coupling	■	■	■	21
Coupling with bore	■	■	■	21
Electrical connection for non-explosion-proof actuators				
Electrical connection with plug/socket	●	●	–	22
Expanded connection compartments	■	■	–	22
Double sealed	■	■	–	22
Protection cover	■	■	–	22
Parking frame	■	■	–	22
Electrical connection for explosion-proof actuators				
Plug/socket connector for explosion-proof actuators	–	–	●	23
Plug-in terminal connection for explosion-proof actuators	–	–	■	23
Double sealed	–	–	●	23
Protection cover	–	–	■	23
Parking frame	–	–	■	23

¹ For actuators without integral controls, the actuator signals have to be processed accordingly in the higher level controls.

Service conditions

AUMA devices are used worldwide; in all climate zones, in industrial plants of all kinds under special local ambient conditions. AUMA devices have to operate reliably and for a long time under any conditions without requiring major maintenance work. For this very reason, AUMA has focussed on making AUMA devices resistant to the most unfavourable conditions and have adapted their protective measures to the state-of-the-art technology.



AUMA part-turn actuator in the Sahara

Enclosure protection

IP 67

AUMA actuators conform to enclosure protection IP 67 according to EN 60 529. IP 67 means protection against immersion up to maximum of 1 m of head of water for max. 30 minutes.

IP 68

AUMA actuators are available with improved enclosure protection IP 68 according to EN 60 529. IP 68 means protection against submersion up to 6 m of head of water for max. 72 hours. During submersion up to 10 operations are permissible.

In order to guarantee the enclosure protection IP 68, suitable cable glands must be used. They are not part of the standard supply, but can be provided by AUMA on request.

Ambient temperatures

Types	Actuator types	Versions	Temperature range
SG	Part-turn actuators for open-close and positioning duty	Standard Low temperature Extreme low temperature	- 25 °C ... + 80 °C - 40 °C ... + 60 °C - 60 °C ... + 60 °C
SGExC	Explosion-proof part-turn actuators for open-close and positioning duty	Standard Low temperature Extreme low temperature	- 20 °C ... + 40 °C/60 °C ¹ - 40 °C ... + 40 °C/60 °C ¹ - 50 °C ... + 40 °C/60 °C ¹
SGR	Part-turn actuators for modulating duty	Standard Low temperature	- 25 °C ... + 60 °C - 40 °C ... + 60 °C

If an actuator is equipped with directly mounted AUMA MATIC or AUMATIC integral controls, the maximum permissible ambient temperature is + 70 °C, unless the actuator requires a lower temperature limit.

¹ For the temperature range + 60 °C, special sizing is required for temperature class T4.

Corrosion protection/colour

Standard (KN)

The standard AUMA corrosion protection KN is a high quality coating. This is suitable for outdoor installation and for slightly aggressive atmospheres with a low level of pollution.

KS

AUMA recommends this corrosion protection class for installation in occasionally or permanently aggressive atmospheres with a moderate pollutant concentration.

KX

AUMA recommends this corrosion protection class for installation in aggressive atmosphere with high humidity and a high pollutant concentration.

Colour

The standard colour of the finish coating is grey (DB 702, similar to RAL 9007). Other colours are available on request.

Explosion protection

For the installation of actuators in potentially hazardous or explosive areas, special protective measures are required. These are stipulated in the European Standards EN 50 014, 50 018, and 50 019. The PTB (Physikalisch Technische Bundesanstalt, the German national test authority) and the BVS (German Mining Test Facility) as European test authorities have certified the conformity of the equipment with the mentioned standards.

Explosion protection classification of the part-turn actuators

The explosion-proof versions of the AUMA SGExC part-turn actuators correspond to the following explosion protection classes:

- II2G EEx de IIC T4
- II2G c IIC T4
- II2D Ex tD A21 IP6X T130°C

Functions

The function of an actuator is to electrically set a defined valve position, triggered by an operation command, e.g. from a process control system.

This seemingly simple task has to be performed under the most diverse conditions, depending on the application. This includes different switch-off criteria and safety concepts. The connection to the control system also requires special actuator configuration to provide the optimum solution for this task.

Furthermore, different protective equipment is required protecting both actuator and valve against damage or even destruction.

The functions described in the following can be used to find a solution to more than 90 % of the possible tasks.

In all AUMA subsidiaries, engineers will help you in finding the suitable actuator, especially for applications with special requirements.

Motor operation

During normal operation, the actuator is operated via the actuator controls which receive operation commands from the control room. If the actuator is also to be operated locally, additional local controls are required. If the actuator is equipped with optional integral AUMA controls, the local controls and the motor controls are always included.

To meet the special valve automation requirements, AUMA uses specially designed electric motors which have both a compact design and a favourable torque curve. Starting from standstill, they provide a high torque to unseat sticky valves from their end position.

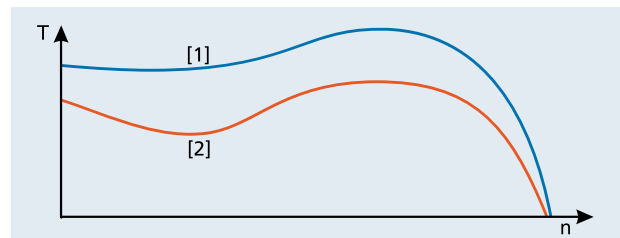

Torque T depending on the output speed n

[1] AUMA 3-ph AC motor

[2] Standard motor with identical power and larger size

Actuators are generally supplied with 3-phase AC motors. These asynchronous motors have a simple design and are robust during operation.

The actuators can also be supplied with 1-phase AC or DC motors.

Manual drive

Electric actuators are always equipped with a handwheel. During commissioning, the actuator is operated manually by using the handwheel to set the end positions and the switching points.

Manual operation can be engaged without using the change-over mechanism. The handwheel can be operated even if the motor is running without endangering persons or the actuator.

The handwheel does not rotate during motor operation.



Switching off in the end positions

Depending on the design of the valve and/or the application, the actuator is switched off in the end positions according to one of the following procedures stipulated by the valve manufacturer:

- Limit seating, i.e. at one of the set switching positions
- Torque seating. This type of seating is used if the valve has to be moved to end position CLOSED at a defined torque.

AUMA actuators contain two independent measuring systems, limit switching and torque switching (see page 14).

The type of seating has to be considered in the actuator controls.

Limit seating

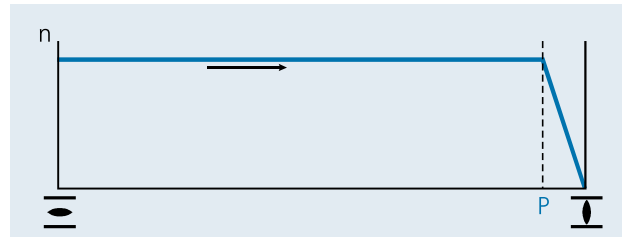

Running speed n depending on the travel

The actuator runs at a designated running speed up to tripping point P . When setting P , you have to account for the overrun of the actuator. The overrun of part-turn actuators is predominantly generated by the delay time of external controls, e.g. a PLC.

Torque seating

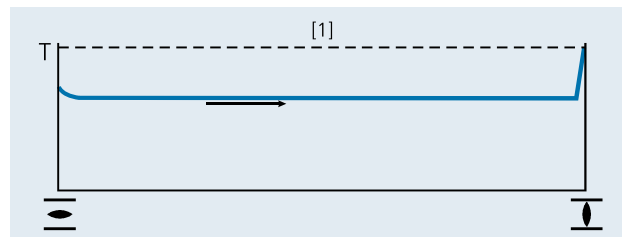

Torque T depending on the travel

[1] Set tripping torque

When reaching end position CLOSED the torque increases within the valve seat until the actuator is switched off after reaching the set value.

Functions

Control unit with limit and torque switching

Controls can switch off the actuator via limit and torque seating in the end positions or in case of overload. The control unit (refer to illustration on page 8) includes two independent measuring systems which measure the travel or the torque present at the output drive.

Control unit with micro switches

Travel and incoming torque are recorded via a counter gear mechanism and a lever system within the control unit. When the set switching points are reached, the corresponding micro switches are operated via cams.

The control unit contains:

- one torque switch each for the directions OPEN and CLOSE,
- one limit switch each for the end positions OPEN and CLOSED.

The switch signals trip the actuator according to the type of seating required.

Limit and torque switches are available in several versions:

- Single switch
one NC and one NO contact, not galvanically isolated.
- Tandem switch (option)
for switching two different potentials.
A tandem switch provides the electrical connection with the signal for switching off the actuator and another galvanically isolated signal.
- Triple switches (option)
For applications where three different potentials are to be switched. The switch consists of one single and one tandem switch.
- Intermediate position switch (option)
The so-called DUO limit switching contains an additional switch for setting intermediate switching points outside the end positions for each direction.

In the basic version the switch contacts are made of silver. For voltages between 5 V and 50 V and extremely low currents, switches with gold plated contacts are recommended.

Control unit with magnetic limit and torque transmitter (option)

Position and the available torque are continuously recorded via Hall sensors. The valve position and the torque present within the valve are available as continuous signals.

The magnetic limit and torque transmitter is designed to measure immediately the precise valve position once the power supply has been restored after a power failure. A reference operation is not required. The system does not require auxiliary energy, e.g. battery.

If the control unit is used with an MWG, the actuator has to be equipped with the integral AUMATIC actuator controls. A significant advantage of this combination is that all actuator parameters can be set without opening the housing or the use of any tools.

Overload protection of the valve

The torque switching acts as overload protection for the whole travel. Thereby the valve is protected against damage or destruction due to excessive torques.

If excessive torque builds up at the valve's closing element in an intermediate position, e.g. due to a trapped object, the torque switches will trip as soon as the set tripping torque is exceeded.

Correct processing of the torque signal is the prerequisite for fully functional overload protection. This is automatically ensured for actuators with AUMA integral controls.

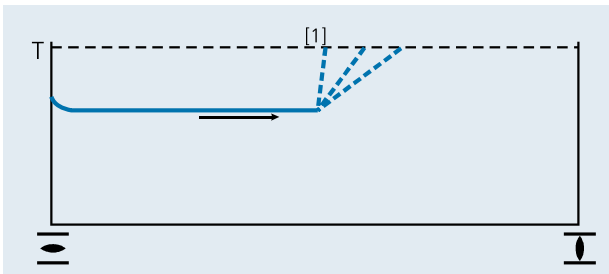

Torque T depending on the travel

Protection against unauthorised operation (option)

The position of freely accessible valves may not be changed by unauthorised personnel.

This can be prevented by securing the actuator handwheel by means of a locking device.



Functions

Protection of the motor against overheating

The windings of the 3-phase AC and 1-phase AC motors contain thermostiches or PTC thermistors which trip as soon as the temperature within the motor exceeds 140 °C. Should this be the case, the controls have to switch off the actuator.

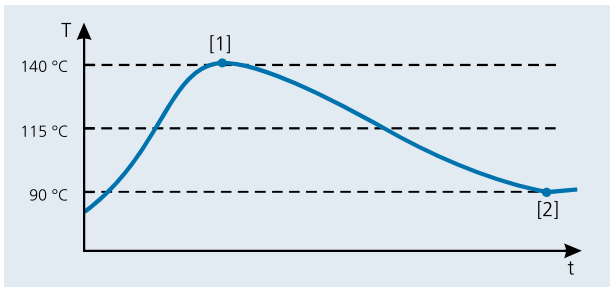

Motor temperature curve against time

[1] Tripping point

[2] Switch-on point

Thermostiches or PTC thermistors offer far better protection than thermal overload relays, since the temperature rise is directly measured at the motor windings.

As standard, thermostiches are used. If an AUMA NORM actuator is supplied with the optional PTC thermistors instead of thermostiches, a suitable PTC tripping device must be included in the external controls. If the actuator is equipped with integral controls, the PTC tripping device is already included.

Protection against accidental changing of the valve position

High torques can develop at the valve disc due to the differential pressure, especially in butterfly valves. It is important that the valve position does not change as a result of this.

Self-locking and self-braking

Due to their design, the part-turn actuators counteract torques acting upon the output side with a load. This load is not only large enough to stop change in the valve position from standstill (self-locking), but it also operates the closing element to a standstill if the actuator is switched off (self-braking).

Signals/indication

Signals are the foundation for controlling a process flow. For this reason, actuators provide a number of signals which indicate the operational status of the actuator and of the valve.

Many applications require that the actuator or the valve status can be provided locally. Depending on the equipment, the actuator offers various possibilities.

Feedback signals

The actuator signals are sent and evaluated by the actuator controls. For an AUMA NORM actuator, the signals are processed via external actuator controls, e.g. a PLC. For AUMA MATIC or AUMATIC actuators, the actuator signals are processed directly and locally; the higher level controls are provided with evaluated signals.

Actuator signals

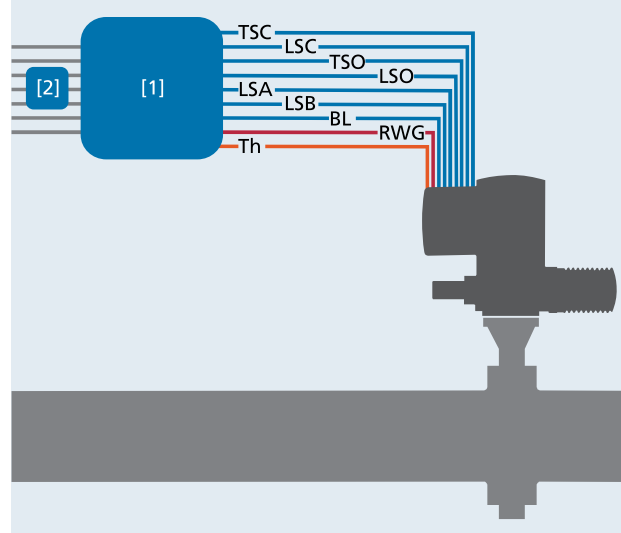

AUMA actuator fully equipped

- [1] Actuator controls, e.g. PLC
- [2] Feedback signals to the DCS
- [TSC] Torque switch signal in direction CLOSE
- [LSC] Limit switch signal in end position CLOSED
- [TSO] Torque switch signal in direction OPEN
- [LSO] Limit switch signal in end position OPEN
- [LSA] Intermediate position switch signal in direction CLOSE (option)
- [LSB] Intermediate position switch signal in direction OPEN (option)
- [BL] Blinker transmitter signal, option for actuators for modulating duty
- [RWG] Electronic position transmitter 0/4 – 20 mA (option)
- [Th] Thermo-switch

Signals/indication

<i>Feedback signals</i>	
Feedback	Actuators without integral controls (AUMA NORM)
	When using tandem switches instead of the common single switches, the signals can be fed back twice as galvanically isolated signals.
Valve end positions	Limit and torque switch signals have to be evaluated within the external controls. When processing the signals it has to be considered whether the actuator is limit or torque seated in the end positions. For limit seating, the end position signal is generated by evaluating the limit switch signals. For torque seating, the end position feedback signal is generated by combining limit and torque switch signals.
Valve position	An optional position transmitter provides the external controls with the valve position either as a voltage signal or as a 0/4 – 20 mA current signal.
Intermediate positions, e.g. for starting up a pump when reaching a particular valve position	As an option, the actuator contains two additional intermediate position switches, one for each direction (DUO limit switching)
Actuator/valve is operated	Can be provided by a blinker switch which is included in the basic version of open-close actuators and optionally available for modulating actuators.
Fault (excessive temperature)	The higher level controls have to monitor the thermoswitches installed in the actuator motor. Tripping of the thermoswitches has to switch off the actuator immediately to prevent it from being damaged. Consequently, the external controls have to generate a fault signal to be able to detect and eliminate a fault.
Fault (torque fault)	Tripping of a torque switch in mid-travel has to lead to immediate switching off of the actuator. Torque switch tripping in one of the end positions can also be part of normal operation. This is identified by the limit switch tripping at the same time. In all other cases, the tripping of the torque switch is to be interpreted as a fault. To be able to identify and eliminate a fault, the external controls have to provide a fault signal.

Feedback signals for actuators with integral controls

Integral controls have the following advantages:

- For actuators with integral controls, the above mentioned feedback signals are directly made available. This reduces the number of signals to be led to the higher level controls.
- By means of enhanced diagnostic functions, the AUMATIC provides a number of other feedback signals which can be used if required.
- The controls have binary and analogue outputs or alternatively a fieldbus interface which can be used to transmit the signals to the DCS.

Further information on these actuator types is available in the brochures:

- Product description
Actuator controls AUMA MATIC
- Product description
Actuator controls AUMATIC

Local indication

Actuators without integral controls (AUMA NORM)



AUMA part-turn actuators are always equipped with a mechanical position indicator which can be used to view the valve position and also as a running indication. The mechanical position indicator is clear and fully legible, even from a long distance.

For AUMA NORM actuators, the actuator signals are exclusively processed by the external actuator controls. If signals generated within these controls are required as a local indication, additional display elements and signal channels become necessary.

Actuators with integral controls

Actuators with integral controls can also be equipped with the mechanical position indicator. Furthermore, the controls are complete with indication lights, or, in the case of the AUMATIC, a display, which indicate the operation status locally.

For more detailed information on local indication, refer to the following brochures:

- Product description
Actuator controls AUMA MATIC
- Product description
Actuator controls AUMATIC

Integral controls

The integral controls evaluate the actuator signals and operation commands and perform the required switching procedures automatically and without delay, using the installed switchgear, reversing contactors or thyristors. The controls make the evaluated actuator signals available to the higher level controls as feedback signals.

Actuators with integral controls are ready for operation immediately after establishing the power supply and can be operated via the operating elements.

AUMA MATIC

In its basic version, the AUMA MATIC is ideal for simple OPEN - CLOSE applications.

The AUMA MATIC provides end position indication, the selector switch position and a collective fault signal, all as feedback signals.

The behaviour of the AUMA MATIC can be adapted to the application via programming switches, e.g. programming of the type of seating.

Options:

- Three-position controller
- Fieldbus interface (Profibus DP or Modbus RTU)



AUMA MATIC local controls with push buttons, selector switches and indication lights

Further literature

Detailed information can be found in the brochure 'Product description, Actuator controls AUMA MATIC'

AUMATIC

As well as the AUMA MATIC's basic functionality, the AUMATIC offers some other advantages, e.g.

- programmable signal relays
- non-intrusive setting (option)
- adaptive positioner (option)
- fieldbus interfaces for Profibus DP, Modbus RTU, DeviceNet, Foundation Fieldbus (option)
- monitoring and diagnosis
- logging of operating data
- cable-based or wireless programming interface for connecting a programming device



AUMATIC local controls with push buttons for operation and programming, selector switch, display with plain text display, indication lights and programming interface.

Further literature

Detailed information can be found in the brochure 'Product description, Actuator controls AUMATIC'

Valve attachment

The actuator is mounted to the valve using a mounting flange standardised according to EN ISO 5211.

The torque is transmitted to the valve shaft via a separate coupling. In the basic version, the coupling is unbored; it may also be provided with the bores shown below.

In case of special valve designs with a low valve stem or if an intermediate flange is required between actuator and valve, the coupling might be too short. For such cases, the coupling is also available as extended version.

To prevent the coupling from sliding too far into the actuator, e.g. when mounting the actuator with the flange facing upwards, the coupling can be fitted with an axial locking mechanism.

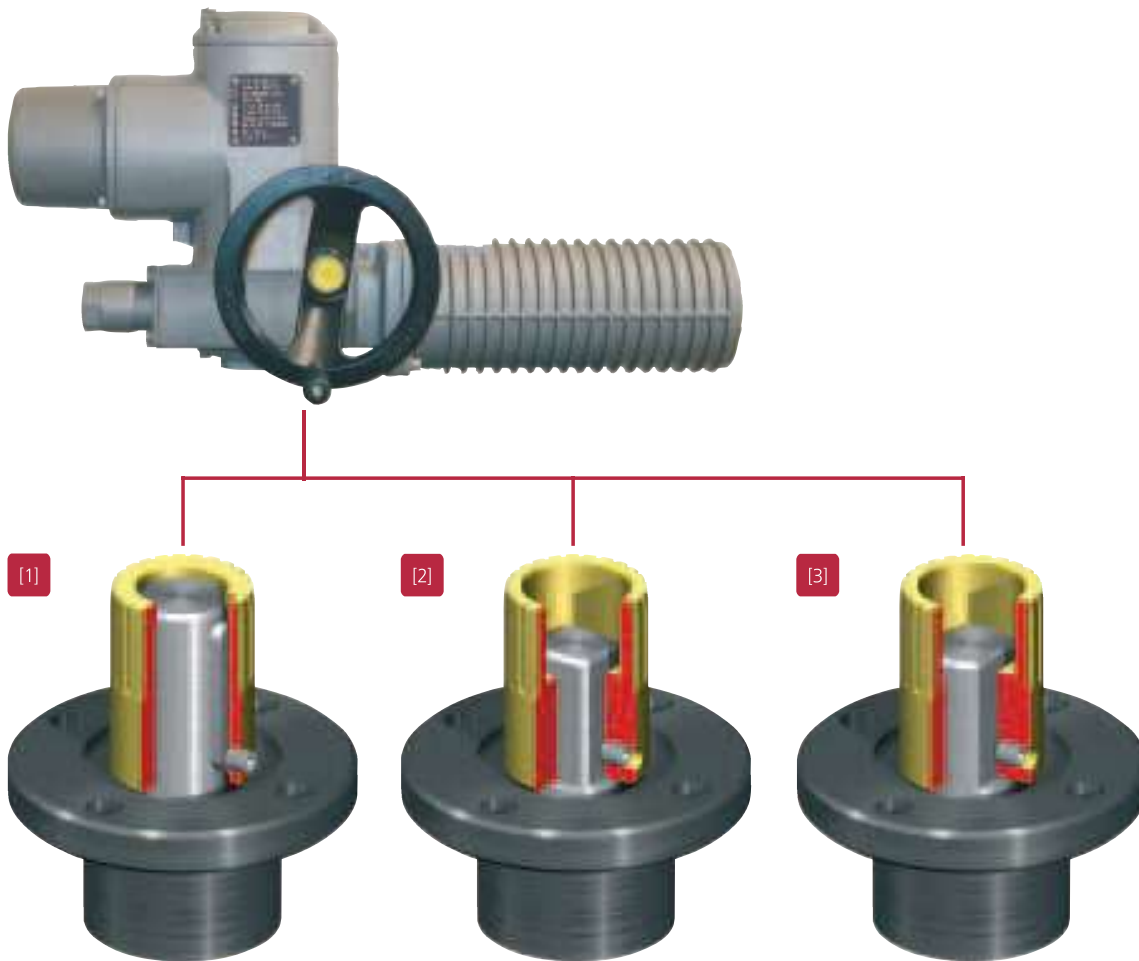

If the coupling is bored, it is supplied with a grub screw to fasten the coupling to the valve shaft.

[1] Bore with keyways

The bore according to EN ISO 5211 can be supplied with one, two, three or four keyways. The keyways conform to DIN 6885 P1. For keyways with other dimensions please contact AUMA.

[2] Square bore

according to EN ISO 5211 or with special diameter.

[3] Bore with two-flats

according to EN ISO 5211 or with special diameter.

Electrical connection for non-explosion-proof actuators

AUMA non-explosion-proof actuators use a “plug-in” type electrical connection. This applies to both power supply and signal cables. The wiring made during installation remains undisturbed, even if the actuator has to be disconnected from the mains or the DCS, e.g. for maintenance purposes. The actuator can be quickly reconnected, wiring errors are avoided.

The electrical connection is available in different sizes. The number of cable entries may vary. The cable entries usually have metric threads, Pg- or NPT-threads are also available.

The electrical connections can be used for actuators with or without controls.

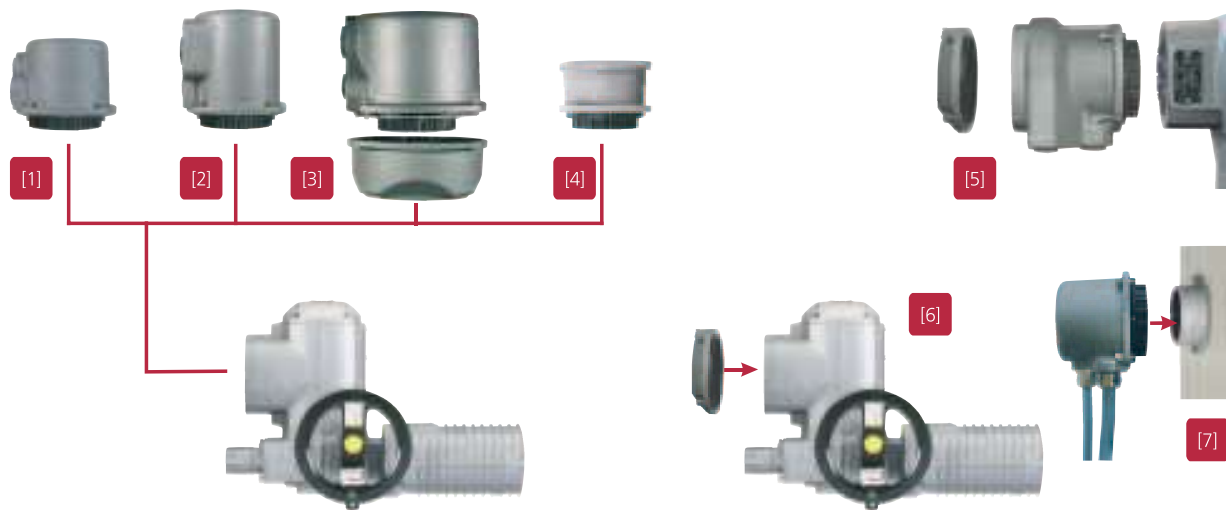

All electric connections are based on the AUMA plug/socket connector with 50 screw-type terminals for connecting the signal cables and three screw-type connections for connecting the supply voltage.

[1] **Standard S**

with three cable entries. The diameter is 100 mm.

[2] **Enlarged terminal compartment SH (option)**

with up to six cable entries

[3] **Enlarged terminal compartment SE (option)**

with three cable entries. The diameter is 135 mm. An intermediate frame is required for adapting to the actuator housing.

[4] **Double sealed intermediate frame (option)**

When removing the plug cover or due to leaky cable glands, ingress of dust and water into the housing is possible. This is prevented by inserting the double sealed intermediate frame between the electrical connection and actuator housing. The enclosure protection, IP 67 or IP 68, will not be affected, even if the electrical connection is removed. The double sealed intermediate frame can be combined with any of the illustrated electrical connections.

[5] **Fieldbus connection SD**

If the actuator is equipped with actuator controls with a fieldbus interface, a special electrical connection is required. The connection of the power supply does not differ from the other electrical connections, a connection board for connecting the fieldbus cables is integrated into the plug.

[6] **Protection cover**

for protecting the plug compartment when plug is removed.

[7] **Parking frame**

for safe mounting of a disconnected plug.

Electrical connection for explosion-proof actuators

AUMA explosion-proof actuators use a “plug-in” type electrical connection. This applies to both power supply and signal cables. The wiring made during installation remains undisturbed, even if the actuator has to be disconnected from the mains or the DCS, e.g. for maintenance purposes. The actuator can be quickly reconnected and wiring errors are avoided.

Explosion-proof connections are always double sealed: The flameproof enclosure inside the actuator remains intact even after removing the plug cover.

The electrical connection is either designed in the protection type “Increased safety” or “Flameproof enclosure”.

The electrical connections can be used for actuators with or without controls.

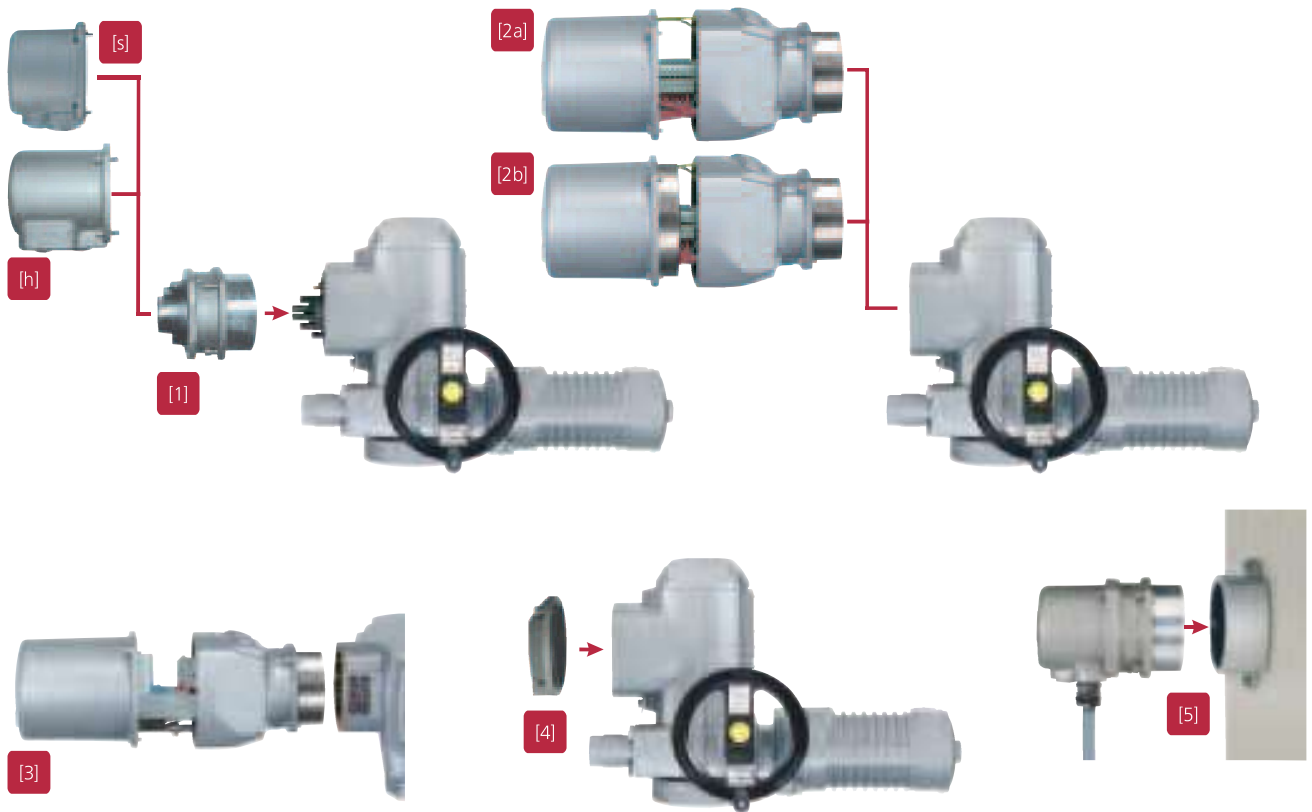

[1] Plug/socket connector with screw-type terminals KP

with 38 screw-type connections for the signal cables. This connection type is the standard connection for explosion-proof actuators, even for those with a fieldbus interface. The connection can be supplied with a standard plug cover (s) with three cable entries or with a high (h) plug cover with up to six cable entries. The connection with the high (h) cover is also used for devices with integral controls and fieldbus interface.

[2] Plug/socket connector with spring cage terminal blocks KES

with up to 50 spring-cage terminal blocks for connecting signal cables. Used with operating voltages exceeding 525 V and/or if a large number of terminals are required. The electrical connection has up to 6 cable entries. The connection is available in protection type “Increased safety” [2a] or “Flameproof enclosure” [2b].

[3] Plug/socket connector with FO coupler KES

This connection type is used for actuators with AUMATIC integral controls with a fieldbus interface and signal transmission via fibre optics. The design basically corresponds to the plug/socket connector with spring cage terminals with the addition of an FO coupler.

[4] Protection cover

for protecting the plug compartment when the plug is removed.

[5] Parking frame

for safe mounting of a disconnected plug. The parking frame with mounted plug is protected against the ingress of both dust and water.

Technical data

Part-turn actuators for open-close duty

The following data is valid for actuators with 3-phase AC motors. For data for other motor types refer to the separate technical data sheets.

Type	Operating times at 50 Hz ¹	Setting range for tripping torque [Nm]	Valve mounting flange	
	[s]		Standard (EN ISO 5211)	Option (EN ISO 5211)
SG/SGExC 05.1	4 – 32	100 – 150	F05	F07
SG/SGExC 07.1	5.6 – 32	120 – 300	F07	F10
SG/SGExC 10.1	11 – 63	250 – 600	F10	F12
SG/SGExC 12.1	22 – 63	500 – 1,200	F12	F14, F16

¹ Fixed operating times, where each operating time is 1.4 times longer than the previous

Part-turn actuators for modulating duty

The following data is valid for actuators with 3-phase AC motors. For further data refer to the separate technical data sheets.

Type	Operating times at 50 Hz ¹	Setting range for tripping torque [Nm]	Permissible average torque for modulating duty	Valve mounting flange	
	[s]		[Nm]	Standard (EN ISO 5211)	Option (EN ISO 5211)
SGR 05.1	16 – 32	100 – 150	50	F05	F07
SGR 07.1	16 – 32	120 – 300	100	F07	F10
SGR 10.1	22 – 63	250 – 600	200	F10	F12
SGR 12.1	32 – 63	500 – 1,200	400	F12	F14, F16

¹ Fixed operating times, where each operating time is 1.4 times longer than the previous

Supply voltages/mains frequencies

The standard supply voltages are listed below. Not all actuator versions or sizes are available with all motor types or voltages/frequencies. SGR modulating actuators are only available with 3-phase AC motors. For detailed information refer to the separate electric data sheets.

3-phase AC

Voltages [V]	Frequency [Hz]
220; 230; 240; 380; 400; 415; 500; 690	50
220; 380; 400; 440; 460; 480; 575	60

DC

Voltages [V]
24; 110; 220

1-phase AC

Voltages [V]	Frequency [Hz]
230	50
115	60

Lifetime for part-turn actuators for open-close duty

An operation cycle is based on an operation from CLOSED to OPEN and back to CLOSED, with a travel of 90° each.

Type	Operating cycles
SG/SGExC 05.1	20,000
SG/SGExC 07.1	20,000
SG/SGExC 10.1	15,000
SG/SGExC 12.1	10,000

Lifetime of part-turn actuators for modulating duty

The lifetime depends on the load and the number of starts. A high starting frequency will rarely improve the modulating accuracy. To reach the longest possible maintenance and fault-free operating time, the number of starts per hour chosen should be as low as possible for the process. This can be achieved by setting the modulating parameters accordingly.

Type	Modulating steps in millions	Number of starts ¹
	min.	max/h
SGR 05.1	2.5	600
SGR 07.1	2.5	600
SGR 10.1	2,5	600
SGR 12.1	2.5	600

¹ Based on the permissible average torque in modulating duty according to 'Technical data SGR 05.1 – SGR 12.1'

Motor duty types (according to IEC 34-1)

Depending on service conditions, open-close or modulating duty and running time, the motors are available with different duty types. The motors are not designed for permanent operation S1, but for short-time duty S2 or intermittent duty S4. The latter meet the valve automation requirements. Additional cooling of the motors is not required while a high enclosure protection is maintained.

The time information for short-time duty S2 indicates the maximum permissible running time without interruption; the motor then has to cool down to ambient temperature. The percentages given for intermittent duty S4 indicate the percentage of the operation time in relation to the pause time.

Type	3-phase AC	1-phase AC	DC
SG 05.1 – SG 12.1	S2 - 15 min	S2 - 15 min	S2 - 15 min
SGExC 05.1 – SG 12.1	S2 - 10 min	S2 - 10 min	S2 - 10 min
SGR 05.1 – SGR 12.1	S4 - 25 %	–	–

Mounting position

AUMA actuators (with or without integral controls), can be operated without restriction in any mounting position.

Certificates

EU directives

Declaration of incorporation in accordance with Machinery Directive

According to this EU directive, AUMA actuators, actuator controls and valve gearboxes are not complete machines. This means that a Declaration of conformity in accordance with the Machinery Directive cannot be issued by AUMA. AUMA's Declaration of Incorporation confirms that during the design stage of the devices, the standards mentioned in the Machinery Directive were applied. The Declarations of Incorporation are included in the operation instructions of the devices.

Only by mounting the devices to other components (valves, pipelines etc.) a 'machine' within the meaning of the directive is formed. Before commissioning this machine a Certificate of Conformity must be issued.

Certificate of conformity in accordance with Low Voltage, EMC, and ATEX directive

AUMA actuators fulfil the requirements of these EU directives, which has been proved in extensive tests. Therefore AUMA offers a Declaration of Conformity.

The Declarations of Conformity are included in the operation instructions of the devices.

Compulsory marking with CE mark

AUMA products meet the requirements of the mentioned EU directives. The name plate is therefore marked with the CE mark.



Final inspection record

After assembly, all actuators are thoroughly tested according to AUMA's inspection specification and the torque switches are calibrated. The procedure is recorded on the final inspection record.

Certificates

To prove the suitability of the devices for special applications, notified bodies perform type tests on the devices. One example are the tests to which explosion-proof devices are subjected. If a device has passed the test, this is recorded in a certificate. For all explosion-proof devices mentioned in this brochure, the relevant certificates can be provided.

Where can I get the certificates?

All certificates and records are provided by AUMA on request either as a hard or digital copy.

The documents can be downloaded from the AUMA website around the clock; some of them are password protected.

■ www.auma.com



The actuator specialist

At AUMA, everything revolves around the electric actuator. In a world where industrial processes have become increasingly complex, concentration is an asset – while still being able to see the bigger picture.

AUMA has to cope with a multitude of requirements from the most different applications and from every corner of the world - this is our daily business. We rise to this challenge by pursuing a clear but flexible product policy – supplying the ideal actuator to every customer.

For this purpose, you have to know your markets. Thinking globally means acting regionally. A comprehensive worldwide sales and service network ensures that there is a competent local contact for every customer.

Since 1964, AUMA has established an excellent brand name in the world of actuators. Reliability and innovation are concepts which are closely linked with AUMA. This is above all to be credited to AUMA's dedicated employees who work enthusiastically on the future of the actuator.



Quality is not just a matter of trust

Actuators must be reliable and dependable. They determine the cycle of accurately defined work processes.

But reliability does not begin in production. It begins with a well thought out design and careful selection of materials. This continues with conscientious production.

At AUMA, quality management is monitored on a daily basis. Numerous customer and independent audits, backed by ISO 9001 and ISO 14001 certification confirm these high standards.



Literature

Further literature

Brochures

- Information
Electric actuators and valve gearboxes according to ATEX directive 94/9/EC for the use in potentially explosive atmospheres
- Product description
Actuator controls AUMA MATIC
- Product description
Actuator controls AUMATIC

Technical data

- Part-turn actuators for open-close duty with 3-phase AC motors
SG 05.1 – SG 12.1
- Part-turn actuators for open-close duty with 1-phase AC motors
SG 05.1 – SG 12.1
- Part-turn actuators for open-close duty with DC motors
SG 05.1 – SG 12.1
- Explosion-proof part-turn actuators for open-close duty with 3-phase AC motors
SGExC 05.1 – SGExC 12.1
- Explosion-proof part-turn actuators for open-close duty with 1-phase AC motors
SGExC 05.1 – SGExC 12.1
- Explosion-proof part-turn actuators for open-close duty with DC motors
SGExC 05.1 – SGExC 12.1
- Part-turn actuators for modulating duty with 3-phase AC motors
SGR 05.1 – SGR 12.1

Furthermore there are electrical data sheets, dimension sheets, proposed wiring diagrams and wiring diagrams available.



The latest issues of all documentation can be downloaded as PDF files from www.auma.com.

Index

A

Ambient temperatures	10
AUMA MATIC	7,20
AUMA plug/socket connector	8
AUMATIC	7,20

C

CE mark	26
Certificates	26
Colour	11
Controls	7
Corrosion protection	11
Coupling	8

E

Electrical connection	8,22 - 23
EMC directive	26
Enclosure protection IP	10
EU directives	26
Explosion protection	11

F

Functional test	26
-----------------	----

H

Handwheel	8
-----------	---

I

Integral controls	7
-------------------	---

L

Lifetime	25
Limit seating	13
Limit switches	14
Limit switching	13
Literature	28

M

Manual operation	8
Modulating duty	5
Motor protection	16
Motors	8,16
Mounting position	25

O

Open-close duty	5
Overload protection	15

P

Painting	11
Parking frame	22 - 23
Plug/socket connector	8,23
Protection cover	22 - 23

PTC thermistors

16

T

Thermoswitches	16
Torque seating	13
Torque switches	14
Torque switching	13,15
Torques	7
Type of seating	13

V

Valve attachment	8,21
------------------	------

W

Wall bracket	7
--------------	---

Europe

AUMA Riester GmbH & Co. KG

Plant Müllheim
DE-79373 Müllheim
Tel +49 7631 809 - 0
riester@auma.com
www.auma.com

Plant Ostfildern-Nellingen
DE-73747 Ostfildern
Tel +49 711 34803 - 0
riester@wof.auma.com

Service Center Cologne
DE-50858 Köln
Tel +49 2234 2037 - 9000
Service@sck.auma.com

Service Center Magdeburg
DE-39167 Niederndodeleben
Tel +49 39204 759 - 0
Service@scm.auma.com

Service Center Bavaria
DE-85386 Eching
Tel +49 81 65 9017 - 0
Riester@scb.auma.com

AUMA Armaturentriebe GmbH
AT-2512 Tribuswinkel
Tel +43 2252 82540
office@auma.at
www.auma.at

AUMA (Schweiz) AG
CH-8965 Berikon
Tel +41 566 400945
RettichP.ch@auma.com

AUMA Servopohony spol. s r.o.
CZ-10200 Praha 10
Tel +420 272 700056 / 704125
auma-s@auma.cz
www.auma.cz

OY AUMATOR AB
FI-02230 Espoo
Tel +35 895 84022
auma@aumator.fi

AUMA France S.A.R.L.
FR-95157 Taverny Cedex
Tel +33 1 39327272
stephanie.vatin@auma.fr
www.auma.fr

AUMA ACTUATORS Ltd.
GB- Clevedon North Somerset BS21 6QH
Tel +44 1275 871141
mail@auma.co.uk
www.auma.co.uk

AUMA ITALIANA S.r.l. a socio unico
IT-20023 Cerro Maggiore (MI)
Tel +39 0331 51351
info@auma.it
www.auma.it

AUMA BENELUX B.V.
NL-2314 XT Leiden
Tel +31 71 581 40 40
office@benelux.auma.com
www.auma.nl

AUMA Polska Sp. z o.o.
PL-41-310 Dabrowa Górnicza
Tel +48 32 261 56 68
R.Ludzien@auma.com.pl
www.auma.com.pl

OOO Priwody AUMA
RU-141400 Moscow
region for mail:
24365 Moscow a/ya 11
Tel +7 495 221 64 28
aumarussia@auma.ru
www.auma.ru

ERICH'S ARMATUR AB
SE-20039 Malmö
Tel +46 40 311550
info@erichsarmatur.se
www.erichsarmatur.se

GRØNBECHE & SØNNER A/S
DK-2450 København SV
Tel +45 33 26 63 00
GS@g-s.dk
www.g-s.dk

IBEROPLAN S.A.
ES-28027 Madrid
Tel +34 91 3717130
iberoplan@iberoplan.com

D. G. Bellos & Co. O.E.
GR-13671 Acharnai Athens
Tel +30 210 2409485
info@dgbellos.gr

SIGURD SØRUM A. S.
NO-1300 Sandvika
Tel +47 67572600
post@sigurd-sorum.no

INDUSTRA
PT-2710-297 Sintra
Tel +351 2 1910 95 00
jpalhares@tyco-valves.com

MEGA Endüstri Kontrol Sistemieri Tic. Ltd. Sti.
TR-06810 Ankara
Tel +90 312 217 32 88
megaendustri@megaendustri.com.tr

CTS Control Limited Liability Company
UA-02099 Kiyiv
Tel +38 044 566-9971, -8427
v_polyakov@cts.com.ua

Africa

AUMA South Africa (Pty) Ltd.
ZA-1560 Springs
Tel +27 11 3632880
aumasa@mweb.co.za

A.T.E.C.
EG- Cairo
Tel +20 2 3599680 - 3590861
atec@intouch.com

America

AUMA ACTUATORS INC.
US-PA 15317 Canonsburg
Tel +1 724-743-AUMA (2862)
mailbox@auma-usa.com
www.auma-usa.com

AUMA Chile Respresentative Office

CL- Buin

Tel +56 2 821 4108
aumachile@adsl.tie.cl

LOOP S. A.

AR-C1140ABP Buenos Aires

Tel +54 11 4307 2141
contacto@loopsa.com.ar

Asvotec Termoindustrial Ltda.

BR-13190-000 Monte Mor/ SP.

Tel +55 19 3879 8735
atuador.auma@asvotec.com.br

TROY-ONTOR Inc.

CA-L4N 5E9 Barrie Ontario

Tel +1 705 721-8246
troy-ontor@troy-ontor.ca

MAN Ferrostaal de Colombia Ltda.

CO- Bogotá D.C.

Tel +57 1 401 1300
dorian.hernandez@manferrostaal.com
www.manferrostaal.com

PROCONTIC Procesos y Control Automático

EC- Quito

Tel +593 2 292 0431
info@procontic.com.ec

IESS DE MEXICO S. A. de C. V.

MX-C.P. 02900 Mexico D.F.

Tel +52 55 55 561 701
informes@iess.com.mx

Corsusa International S.A.C.

PE- Miraflores - Lima

Tel +511444-1200 / 0044 / 2321
corsusa@corsusa.com
www.corsusa.com

PASSCO Inc.

PR-00936-4153 San Juan

Tel +18 09 78 77 20 87 85
Passco@prtc.net

Suplibarca

VE- Maracaibo Estado, Zulia

Tel +58 261 7 555 667
suplibarca@intercable.net.ve

Asia

AUMA Actuators (Tianjin) Co., Ltd.

CN-300457 Tianjin

Tel +86 22 6625 1310
mailbox@auma-china.com
www.auma-china.com

AUMA (INDIA) PRIVATE LIMITED

IN-560 058 Bangalore

Tel +91 80 2839 4655
info@auma.co.in
www.auma.co.in

AUMA JAPAN Co., Ltd.

JP-210-0848 Kawasaki-ku,

Kawasaki-shi Kanagawa

Tel +81 44 329 1061

mailbox@auma.co.jp
www.auma.co.jp

AUMA ACTUATORS (Singapore) Pte Ltd.

SG-569551 Singapore

Tel +65 6 4818750
sales@auma.com.sg
www.auma.com.sg

Al Ayman Industrial. Eqpts

AE- Dubai

Tel +971 4 3682720
auma@emirates.net.ae

PERFECT CONTROLS Ltd.

HK- Tsuen Wan, Kowloon

Tel +852 2493 7726
joeip@perfectcontrols.com.hk

DW Controls Co., Ltd.

KR-153-803 Seoul Korea

Tel +82 2 2113 1100
sichoi@actuatorbank.com
www.actuatorbank.com

Al-Arfaj Engineering Co WLL

KW-22004 Salmiyah

Tel +965 481-7448
info@arfajengg.com
www.arfajengg.com

Petrogulf W.L.L

QA- Doha

Tel +974 4350 151
pgulf@qatar.net.qa

Sunny Valves and Intertrade Corp. Ltd.

TH-10120 Yannawa Bangkok

Tel +66 2 2400656
sunnyvalves@inet.co.th
www.sunnyvalves.co.th/

Top Advance Enterprises Ltd.

TW- Jhonghe City Taipei Hsien (235)

Tel +886 2 2225 1718
support@auma-taiwan.com.tw
www.auma-taiwan.com.tw

Australia

BARRON GJM Pty. Ltd.

AU-NSW 1570 Artarmon

Tel +61 294361088
info@barron.com.au
www.barron.com.au



[1] Multi-turn actuators
SA 07.1 – SA 48.1
Torques from 10 to 32,000 Nm
Output speeds from 4 to 180 rpm

[2] Multi-turn actuators SA/SAR
with controls AUMATIC
Torques from 10 to 1,000 Nm
Output speeds from 4 to 180 rpm

[3] Linear actuators SA/LE
Combination of multi-turn actuator SA
with linear thrust unit LE
Thrusts from
4 kN to 217 kN
Strokes up to 500 mm
Linear speeds
from 20 to 360 mm/min

[4] Part-turn actuators
SG 05.1 – SG 12.1
Torques from 100 to 1,200 Nm
Operating times for 90° from 4 to 180 s

[5] Part-turn actuators SA/GS
Combination of multi-turn actuator SA with
multi-turn gearbox GS
Torques up to 360,000 Nm

[6] Bevel gearboxes
GK 10.2 – GK 40.2
Torques up to 16,000 Nm

[7] Spur gearboxes
GST 10.1 – GST 40.1
Torques up to 16,000 Nm

[8] Worm gearboxes with base and lever
GF 50.3 – GF 250.3
Torques up to 32,000 Nm

AUMA Riester GmbH & Co. KG

P.O.Box 1362
D-79379 Muellheim
Tel +49 7631-809-0
Fax +49 7631-809-1250
riester@auma.com

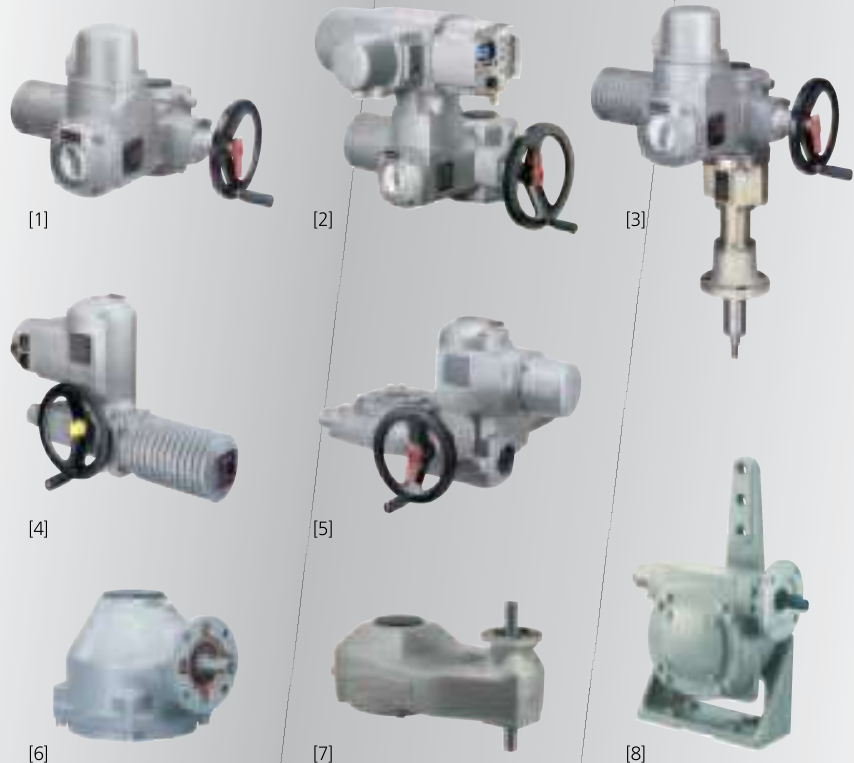

Subject to change without notice.
The product features and technical data provided do not express or imply any warranty.
Y000.217/004/en/1.07

